

CERN 79-02
Intersecting Storage
Rings Division
19 February 1979

ORGANISATION EUROPÉENNE POUR LA RECHERCHE NUCLÉAIRE
CERN EUROPEAN ORGANIZATION FOR NUCLEAR RESEARCH

A DIGITAL TESLAMETER

K. Brand and G. Brun

GENEVA
1979

© Copyright CERN, Genève, 1979

Propriété littéraire et scientifique réservée pour tous les pays du monde. Ce document ne peut être reproduit ou traduit en tout ou en partie sans l'autorisation écrite du Directeur général du CERN, titulaire du droit d'auteur. Dans les cas appropriés, et s'il s'agit d'utiliser le document à des fins non commerciales, cette autorisation sera volontiers accordée.

Le CERN ne revendique pas la propriété des inventions brevetables et dessins ou modèles susceptibles de dépôt qui pourraient être décrits dans le présent document; ceux-ci peuvent être librement utilisés par les instituts de recherche, les industriels et autres intéressés. Cependant, le CERN se réserve le droit de s'opposer à toute revendication qu'un usager pourrait faire de la propriété scientifique ou industrielle de toute invention et tout dessin ou modèle décrits dans le présent document.

Literary and scientific copyrights reserved in all countries of the world. This report, or any part of it, may not be reprinted or translated without written permission of the copyright holder, the Director-General of CERN. However, permission will be freely granted for appropriate non-commercial use.

If any patentable invention or registrable design is described in the report, CERN makes no claim to property rights in it but offers it for the free use of research institutions, manufacturers and others. CERN, however, may oppose any attempt by a user to claim any proprietary or patent rights in such inventions or designs as may be described in the present document.

ABSTRACT

A self-contained instrument for the measurement of magnetic fields is described which consists of a command module and a thermally stabilized Hall plate mounted in a probe. The command module contains the circuitry for the temperature stabilization and the current source for the probe, an analog-to-digital converter and a microprocessor-based control circuitry for the command of the measuring sequences. A read-only memory contains a calibration table for the relation between Hall voltage and magnetic field. The measured field strength can be directly displayed in units of induction (tesla).

The teslameter is provided with a serial teletype input-output port for remote control. An addressing scheme allows up to 16 modules to be connected in parallel and to be controlled via a single teletype channel. This is especially useful if several teslameters are used in a complex measuring set-up.

CONTENTS

| | Page |
|-----------------------------------------------------------------------------------------|------|
| 1. INTRODUCTION | 1 |
| 2. PRINCIPLE OF OPERATION | 2 |
| 3. DETAILS OF THE CIRCUIT | 3 |
| 3.1 The probe and the temperature stabilization circuit | 3 |
| 3.2 The current source | 7 |
| 3.3 The analog input circuit | 8 |
| 3.4 The digital circuit | 9 |
| 4. DETAILS OF THE PROGRAM | 9 |
| 5. THE CALIBRATION | 13 |
| 5.1 Method | 13 |
| 5.2 The calibration set-up | 14 |
| 6. CONCLUSION | 14 |
| 7. SPECIFICATIONS | 15 |
| ACKNOWLEDGEMENTS | 16 |
| REFERENCES | 16 |
| APPENDIX 1 : Illustrative example of messages between two teslameters and a computer | 17 |
| APPENDIX 2 : Function selection switches on the printed circuit board | 18 |
| CIRCUIT DIAGRAMS | |

1. INTRODUCTION

The teslameter was initially developed to back up the moving-coil measuring system for the ISR main field¹⁾. The latter system, while being very accurate, is subject to mechanical wear and since high precision field measurements are only needed in rare instances, an alternative was sought for the majority of applications for which a precision of 10^{-4} is sufficient.

This led to the following requirements for a new system:

- No moving parts;
- Automatic measurement from zero to full field, without changing probes or other interventions;
- Possibility of measuring inhomogeneous fields (within the limitations set by the physical size of the Hall-plate element, $1.6 \times 1.6 \text{ mm}^2$);
- Precision of 10^{-4} of maximum field;
- Remote control of the measuring functions and digital read-out of the field value.

These characteristics are not unique to the above mentioned application and in many circumstances it would be desirable to dispose of such an instrument, e.g. for the measurement of experimental magnets, field monitoring, setting up of bending magnets by field rather than by current to avoid hysteresis, etc. It was, therefore, decided to develop a self-contained, general purpose teslameter which could be used for a broad range of applications.

The resultant instrument, which performs according to the specified requirements, is shown in Fig. 1. With a mass of less than 4 kg, it is easily portable. It requires a 220 V mains connection, and about five minutes after switching on, the instrument is ready and can perform about two field measurements per second.

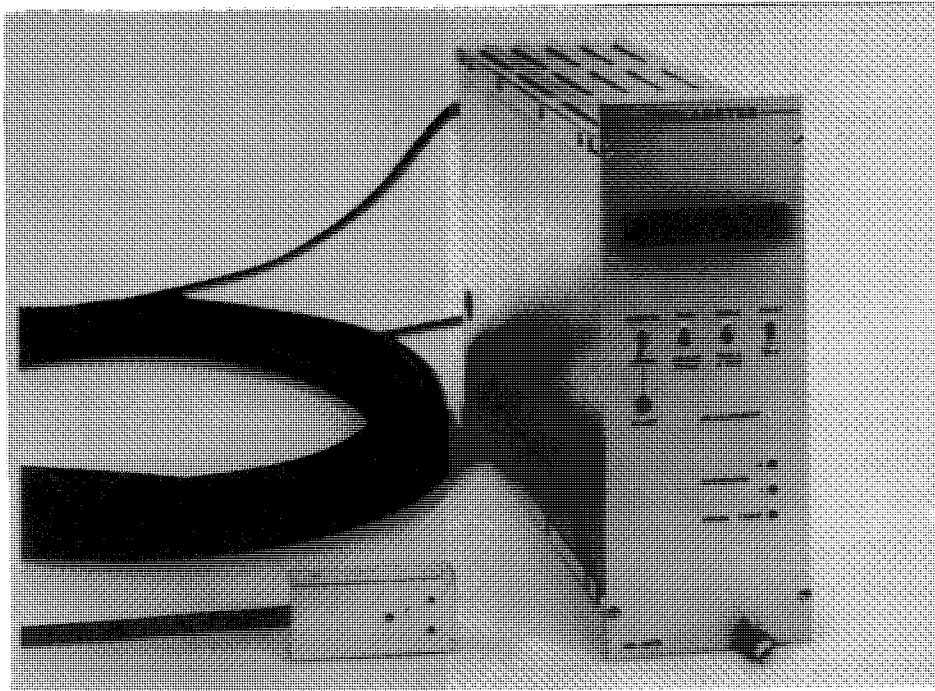

Fig. 1 The teslameter with the measuring head

The equipment is designed to work with cables of up to 10 m between the probe and the electronics module and can be remotely controlled over distances of up to several hundred meters using a standard current-loop teletype link.

The long term stability, as measured on the prototype, has been found to be 10^{-4} which compares well with the short term value.

2. PRINCIPLE OF OPERATION

The requirements listed above can best be met by using a Hall plate as the sensitive element. Typically, a precision of 10^{-4} of full scale requires a temperature stability of a few tenths of a degree Celsius of the Hall plate. In the present design, the Hall plate is therefore mounted on a small copper block, which is held at a constant temperature within a few $1/100^{\circ}\text{C}$ for an ambient temperature variation from 15 to 30°C .

The measuring head with the Hall plate is connected by a cable of up to 10 m length to a module containing the electronic circuitry. The main parts of this module (Fig. 2) are the temperature control circuit, a current source for the Hall-plate driving current, a low level preamplifier for the Hall voltage followed by an analog-to-digital converter (ADC) and finally a microprocessor-based control circuitry.

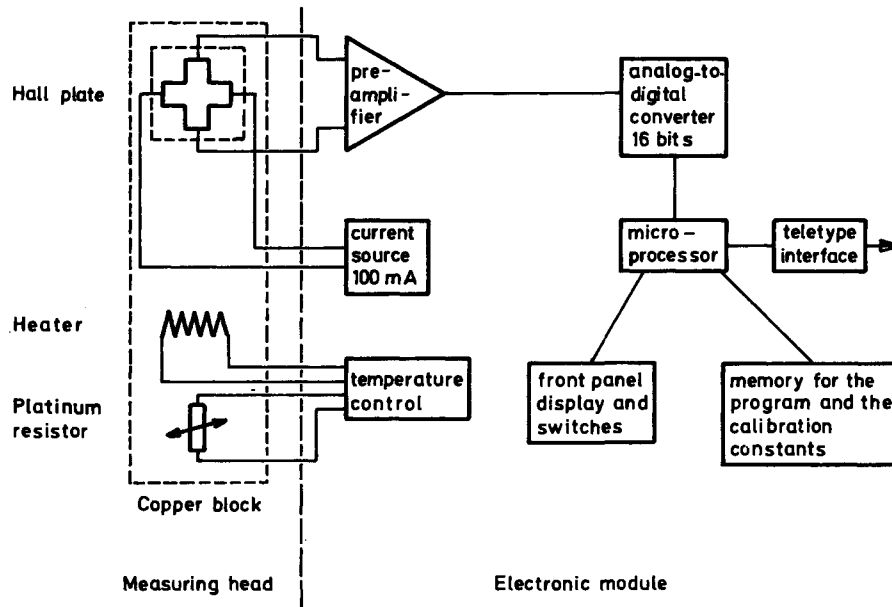

Fig. 2 Block diagram of the digital teslameter

The digitized Hall voltage is converted to a field value using a set of calibration coefficients which are stored in a read-only memory (EPROM). This allows the result of a measurement to be displayed directly in physical units, e.g. in tesla.

All operations, i.e. triggering of a measurement and read-out of the result, may be performed remotely. A current-loop teletype input-output port enables the teslameter to be connected over a distance of several hundred meters to a computer or to another controlling instrument. An addressing feature allows up to 16 teslameters to be connected in

parallel to the same input-output port of the controller, while preserving the possibility of commanding each module separately.

As the sensitivity and nonlinearity of Hall plates vary strongly from one specimen to another, each teslameter has to be calibrated with its own probe. This is done in a calibration magnet using a NMR (nuclear magnetic resonance) magnetometer as reference. The teslameter is connected to a minicomputer and the field as well as the Hall voltage are measured at a certain number of points. A set of coefficients for a third order polynomial spline interpolation between the measured points is then calculated. The coefficients are introduced in a read-only memory which in turn is inserted into the teslameter.

3. DETAILS OF THE CIRCUIT

3.1 The probe and the temperature stabilization circuit

The Hall plate used was of the type SBV 579 manufactured by Siemens, which is well suited for the measurement of d.c. magnetic fields. Its construction in the form of a cross guarantees a good linearity of the Hall voltage vs. field strength. Table 1 gives the principal specifications.

TABLE 1

Principal specifications of Hall plate SBV 597

| | |
|-----------------------------------------|------------------------------------------------|
| Material | InAs |
| Nominal driving current | 100 mA |
| Sensitivity | $>1.1 \text{ V A}^{-1} \text{ T}^{-1}$ |
| Temperature coefficient of Hall tension | $5 \times 10^{-4} \text{ per } ^\circ\text{C}$ |

The desired precision of 10^{-4} of full scale requires a stable temperature of the Hall plate within about 0.1°C . The mechanical design of the measuring head is strongly determined by this requirement. The Hall plate is glued onto a small copper block which can be heated by resistors. The temperature of the copper block is measured by a platinum resistor and the derived signal acts on the heating resistors. The copper block is suspended inside an aluminium case in order to screen the variations of ambient temperature. Figure 3 gives a sketch of the probe head.

For the investigation of the thermal behaviour of the probe, the following assumptions have been made:

- The copper block is isothermal.
- The heat capacity of the air and of the supporting elements around the copper block are neglected.
- The aluminium case is at ambient temperature.

These assumptions are justified by the large difference in thermal conductivity and heat capacity between copper and air. By virtue of these assumptions, the system can be treated as being composed of lumped elements, which considerably simplifies the calculations.

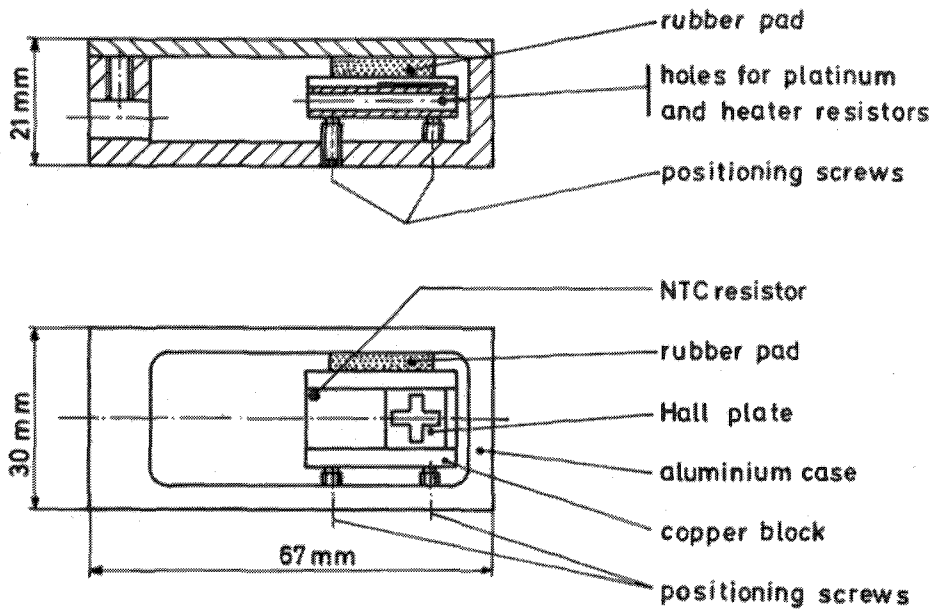

Fig. 3.a) The probe

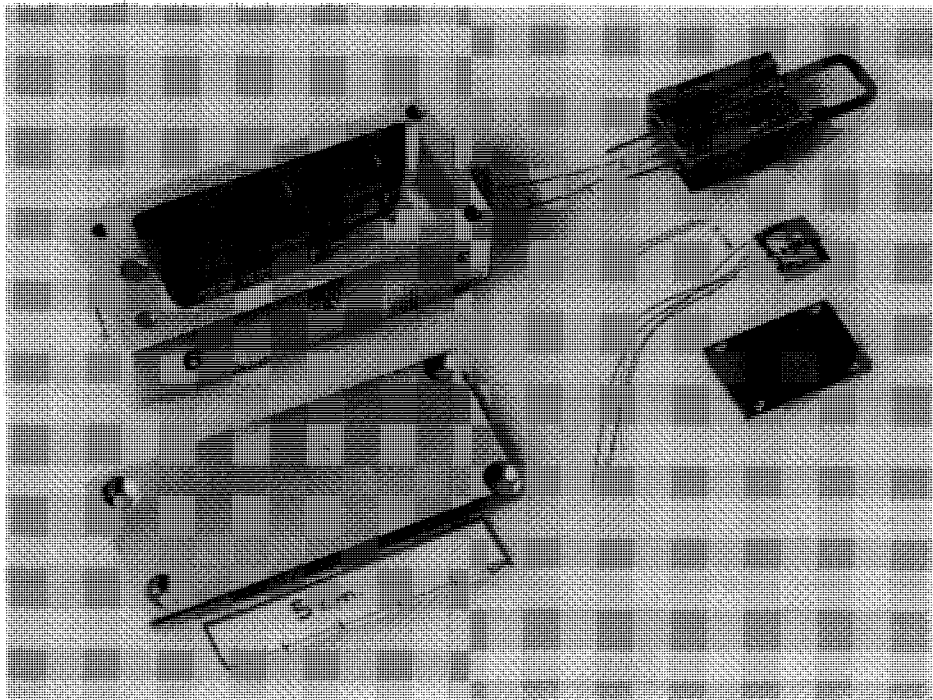

Fig. 3.b) The elements making up the probe

Using the analogies between the equation for heat conduction and Ohm's law and between the definition of the specific heat and of capacitance, an electrical equivalent circuit describing the thermal properties of the probe can be drawn as shown in Fig. 4. The capacitor represents the heat capacity of the copper block. R stands for the heat conduction through the air and the supporting elements from the copper block to the aluminium case. U and U_a represent the temperatures of the copper block and of the aluminium case, respectively, and the current, I, flowing into the capacitor corresponds to the heat generated in the copper block by the heater per unit time.

The transfer function of the equivalent circuit in Fig. 4 is

$$U = \frac{R I + U_a}{1 + pCR} \quad (1)$$

For a feedback circuit which regulates the generated heat according to

$$I = -\beta (U - U_0) \quad (2)$$

where U_0 represents the desired temperature and admitting that the open loop gain $R\beta \gg 1$, the transfer function for the regulated system becomes

$$U = \frac{U_0 + \frac{U_a}{R\beta}}{1 + p \frac{RC}{R\beta}} \quad (3)$$

The feedback system is stable and the desired temperature is approached in an aperiodic way after a change of ambient temperature.

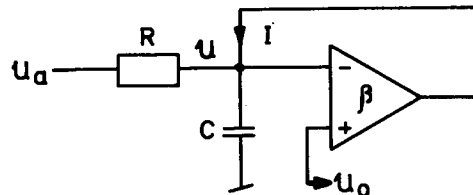

Fig. 4 Equivalent circuit for the temperature stabilization

Unfortunately, it is not possible to satisfy equation (2) with an electronic feedback circuit which is linear. This is due to the fact that the generated heat in the heater resistor depends quadratically on the applied voltage, whereas equation (2) demands a linear dependence. Although it would be possible to design a nonlinear circuit which gives the desired performance according to (2), it has been found that a simpler, linear circuit in practice gives an acceptable performance. The above analysis remains valid for sufficiently small variations of ambient temperature around a given value, where the quadratic dependence of the generated heat can be approximated by a linear one. For each region of U_a , β then takes a different value.

Care has to be taken that the value of β always remains positive. This means that the desired temperature of the copper block must always be well above the ambient temperature so that a certain amount of heating is necessary. For a copper block temperature of 35°C, ambient temperatures of up to 30°C can be tolerated.

Figure 5 shows the diagram of the circuit used. The $100\ \Omega$ platinum resistor which measures the temperature of the copper block forms one arm of a bridge circuit. Since the resistance R_{cable} of the connecting wires between the probe and the command module is not negligible and could influence the stability of the temperature measurement, the bridge arm with the reference resistor is also looped through the connecting cable. Therefore, if the resistance of the connecting cable changes due to ambient temperature changes, this has no effect on the temperature measurement made with the platinum resistor. The error signal coming from the bridge is differentially amplified by a factor 1000 with an instrumentation amplifier. The following power amplifier has a voltage gain of 100. The output voltage is then fed to the heating resistors in the copper block. As a precaution, diodes are added in the output circuit of Fig. 5 in order to cut off the negative swing of the output voltage. This is to avoid a runaway of the temperature if ever the copper block should be well above the equilibrium temperature and the output voltage of the heater amplifier would go negative.

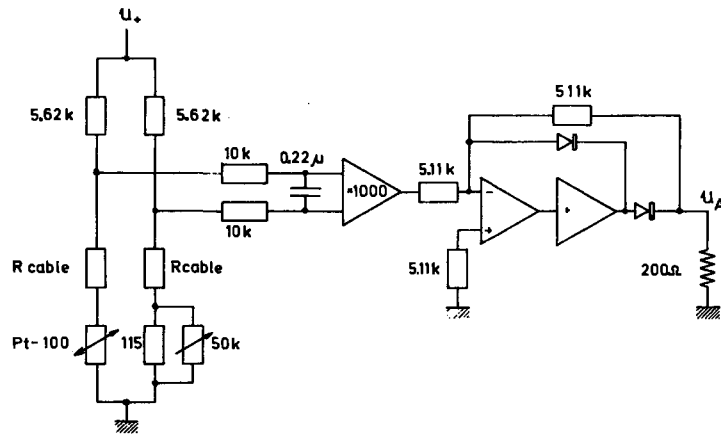

Fig. 5 The temperature stabilization circuit

By estimations, which were checked by measurements, the values of the equivalent circuit in Fig. 4 were obtained. The time constant RC amounts to 300 s and the open loop gain $R\beta$ is 300 for a heater voltage of approximately 10 V, which gives a closed loop time constant of about one second. This is, however, only true for small temperature variations. After switching on, the temperature error is so large that the amplifiers are saturated and a longer time, dependent on ambient temperature, is needed to reach thermal stability. Figure 6 shows the dependence of the copper block temperature on ambient temperature.

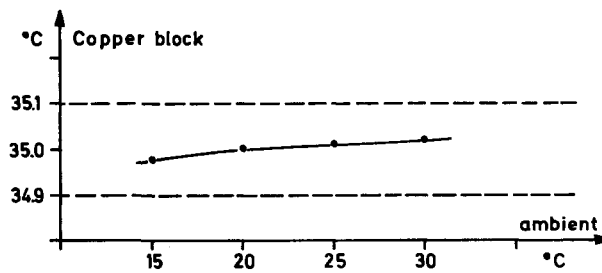

Fig. 6 Copper block temperature versus ambient temperature

In order to have an independent check of the Hall-plate temperature, a second temperature sensitive element, i.e. a NTC resistor, is glued to the copper block near the Hall plate. While the sensitivity of such a device is much greater than for a platinum resistor, its linearity is poor and the variation among specimens is larger. In addition, there are no specifications for the long term stability given in the manufacturer's data sheet. The signal derived from the NTC resistor is fed to two comparators, which are adjusted to the desired temperature $\pm 0.1^{\circ}\text{C}$. An error signal "temperature out of range" is generated if one of the comparators triggers. This happens after switching on the power for the time which is needed to heat the copper block to its final temperature or if the ambient temperature is such that the limits of the stabilization circuit are reached. The error status is indicated on the front panel and can also be read by a remote controller.

3.2 The current source

The voltage developed on the Hall plate is almost proportional to the applied field and to the driving current. Therefore, the stability of the driving current must be better than the required stability of the whole instrument. As the resistance of the Hall plate depends on the applied magnetic field and may vary considerably, a current source with an internal resistance of the order of $10^6 \Omega$ or higher is required. Figure 7 gives the circuit diagram of the current source, which delivers a current of 100 mA.

The main criterion for the design of this circuit was not to get a high internal resistance but a high stability of the current. In fact, a simple open collector current source without a feedback amplifier, i.e. point A in Fig. 7 fixed to a constant potential, would already yield an internal resistance of several $10^5 \Omega$. However, the thermal stability of such a circuit would be very poor. By using a feedback amplifier, the output resistance is increased by the gain of the amplifier, i.e. it is now many orders of magnitude higher than required.

The stability obtained with the circuit of Fig. 7 depends on the stability of the reference resistors, the reference zener diode and the drift of the amplifier. In this case, the zener diode proves to be the most critical element, the worst case figure for the thermal drift being 5×10^{-6} per degree Celsius. This gives a change of 10^{-4} for a 20°C variation in ambient temperature, which is just at the limit of what is acceptable. However, measurements have shown that by selecting zener diodes, a better performance can be obtained.

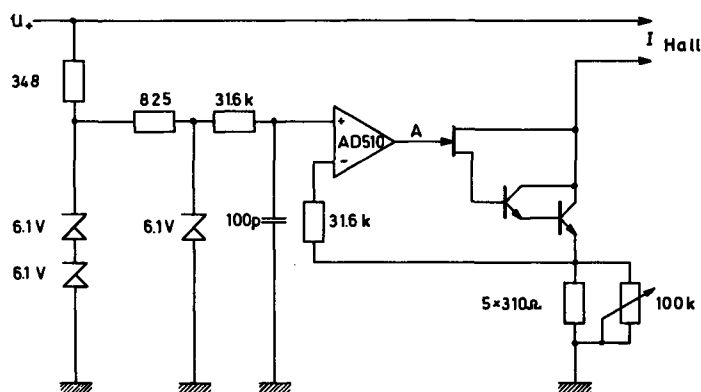

Fig. 7 The current source

3.3 The analog input circuit

Depending on the maximum field to be measured by the teslameter, the Hall voltage has to be amplified by a certain amount before it is digitized. The absolute precision of the teslameter was fixed to be 10^{-4} T. This corresponds to a Hall voltage of roughly $10 \mu\text{V}$ for a driving current of 100 mA . This is about the lower limit for a voltage to be amplified without using a chopper amplifier. The AD510 amplifier which was used has a thermal drift of less than $0.5 \mu\text{V}$ per degree Celsius. It is connected as an inverting amplifier which gives a favourable circuit for thermal stability and noise (Fig. 8). The Hall voltage is measured with respect to ground. This is possible since the current source for the Hall plate is floating. The gain is adjusted in such a way that the output voltage swing corresponding to a full range variation of the magnetic field is 10 V . According to the special requirements, a unipolar or a bipolar ADC can be used to digitize the amplified Hall voltage. In the latter case, magnetic fields of both polarities can be measured.

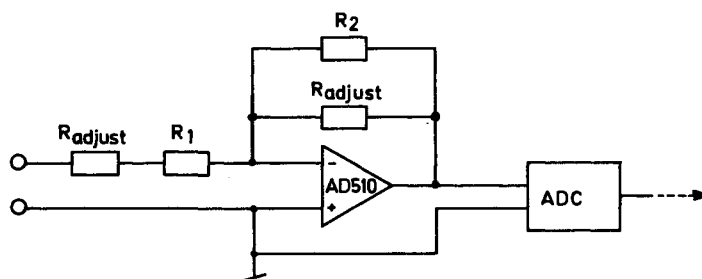

Fig. 8 The analog input circuit

The ADC has a resolution of 16 bits or 15×10^{-6} . The input signal is integrated over 2^{16} clock periods. By suitably choosing the clock frequency, it is possible to make the integration time a multiple of one 50 Hz period within the stability of the mains frequency. This achieves a very high rejection of a.c. components in the magnetic field and in the measuring circuits at 50 Hz and multiples of it. A clock frequency of $327'680 \text{ Hz}$ was chosen which corresponds to an integration over 10 periods of the mains.

The thermal stability of the ADC is specified as 10^{-5} of full scale per degree Celsius, and it is possible to obtain an overall thermal stability including the preamplifier and the ADC of well below 5×10^{-6} per degree Celsius by choosing a resistor with a suitable temperature coefficient in the feedback path of the preamplifier (resistors R_{adjust} in Fig. 8). The temperature dependence of the resistor compensates the dependences of the preamplifier and the ADC. Figure 9 shows the improvement in thermal stability which can be achieved in this way.

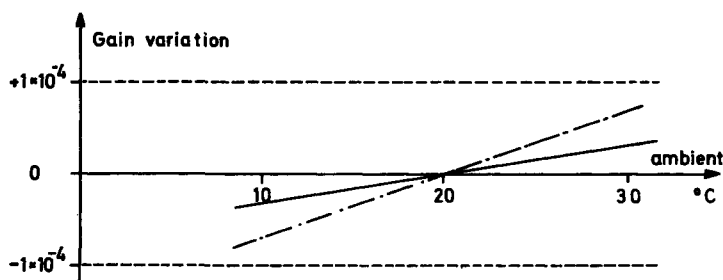

Fig. 9 Temperature dependence of the gain of the input circuit and the ADC
 - . - . - with $\pm 10 \text{ ppm}$ resistors in the feedback path
 - - - - - with selected resistors (R_{adjust} in Fig. 8)

3.4 The digital circuit

The digital circuitry of the teslameter is determined by the use of a microprocessor and the whole logic of operation is contained in the program. This makes the circuit rather straightforward. All digital subsystems, i.e. the ADC and its control signals, the front panel display, control signals coming from the temperature stabilization circuit, front panel and address switches and a teletype receiver - transmitter (UART), are connected to the microprocessor data bus and are therefore handled under software control. Different baud rates and protocols of transmission for the UART may be selected by switches on the printed circuit board. A character received by the UART generates an interrupt on the microprocessor and an interrupt routine address can be specified with switches on the circuit board.

The clock pulses which are needed for the microprocessor, the UART and the ADC are all derived from the same crystal controlled oscillator by different division ratios. When switching on, a reset signal is generated and fed to the microprocessor and the UART. The microprocessor then puts the system under program control in a defined initial state.

The program and also the numerical constants for the calibration of the Hall plate are contained in EPROM's which can be deleted and reprogrammed, if necessary.

4. DETAILS OF THE PROGRAM (Figs. 10.a) and 10.b))

The use of a microprocessor in a digital circuit transfers a great deal of the functional complexity from the circuit board to the program. It is, therefore, surely justified to describe the software in some detail.

One of the advantages of incorporating the logic functions of a system into a program is the possibility of easy changes. This feature was extensively used in the described teslameter and the present software is in fact the result of several revisions.* It is very difficult, if not impossible, to foresee the functions and operational needs of a complex instrument in all details and therefore the possibility to add changes without modifying the hardware is very welcome.

The following subfunctions were needed or considered useful and therefore integrated in the program design:

- triggering of a measurement,
- optional calculation of the field value from the measured Hall voltage with an interpolation algorithm using a calibration table,
- optional output of the result (raw or calculated) via the teletype port,
- continuous or one shot operation,
- local or remote command of the instrument; in the remote mode, the operating conditions are entered via the teletype input port,
- possibility to branch several teslameters in parallel on the same command line, i.e. it must be possible to select each instrument by an individual address.

* The described program corresponds to the software revision TM14.

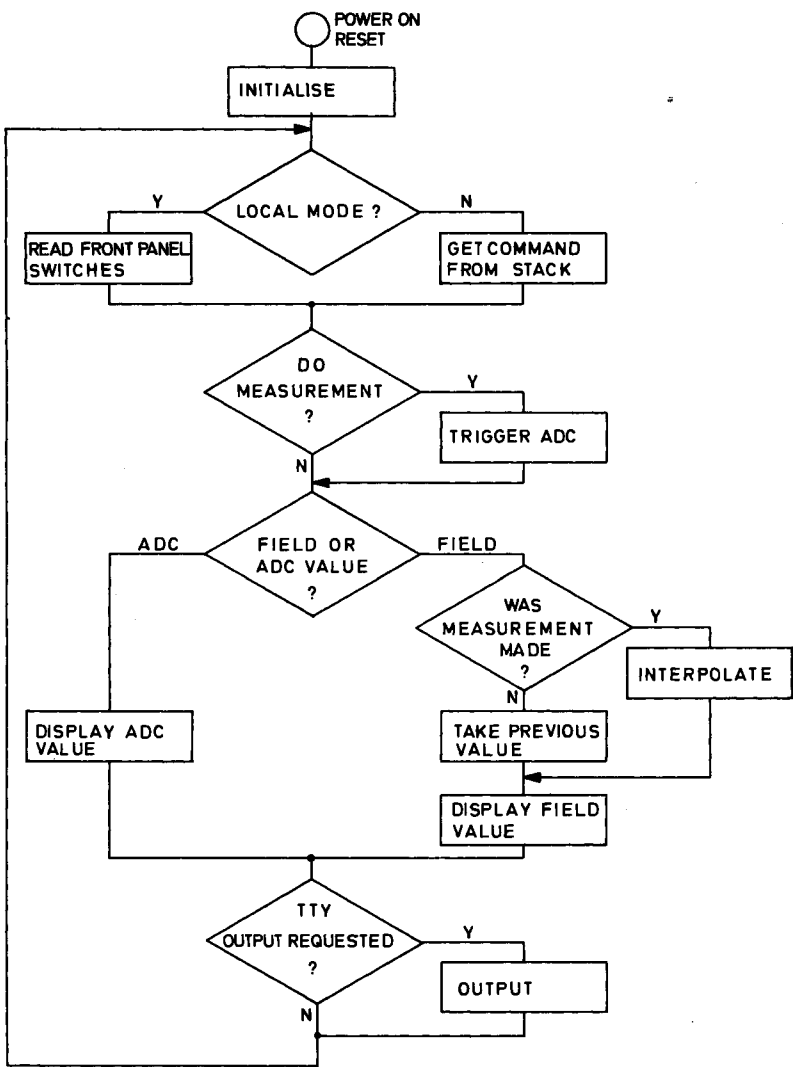

Fig. 10.a) Main program flow diagram

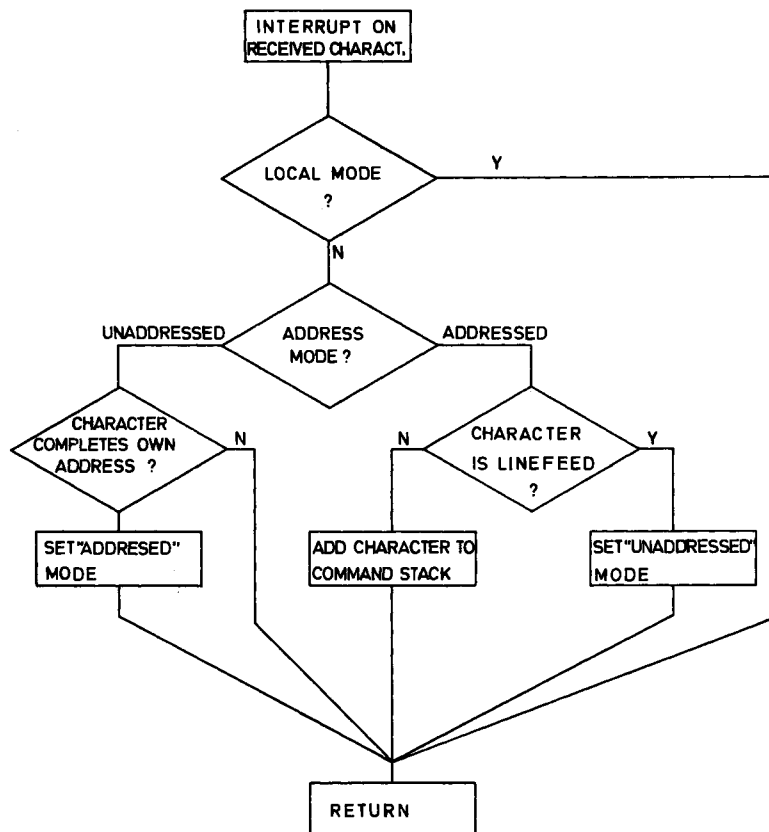

Fig. 10.b) Interrupt routine flow diagram

The program consists of three parts: an initialization routine which is executed after a reset or after switching on and which puts the instrument into a defined state, an interrupt routine which handles all information coming in via the teletype input port, and a main program which coordinates the other activities.

The main program is built as a loop which is continuously executed. For each passage through the loop, a check is made to see whether the operation mode has changed. This happens in the remote mode by the arrival of new commands and in the local mode by changing the front panel switches. According to the result, the subsequent steps, i.e. measurement, calculation and output of the result, are then executed or bypassed.

Table 2 gives a choice of possible combinations of the available options. Each combination can be coded with a single character (the four columns of Table 2 correspond to bits 0 to 3 of the ASCII representation of the character). The wanted mode of operation is then given to the teslameter by sending the corresponding command letter to it. In local mode, front panel switches are used to choose among the same options and measurements are triggered by a push-button.

In the remote mode, there are three additional commands available, one for a general reset of the instrument and the two others for outputting the coefficients of the calibration table. The latter two are used for maintenance purposes only.

TABLE 2

Signification of command letters

| Make a measurement | ADC or field value | Output result to teletype | Operation | Command letter |
|--------------------------------------------------|--------------------|---------------------------|------------|----------------|
| no | field | no | one shot | <blank> |
| no | field | yes | one shot | B |
| no | ADC | no | one shot | D |
| no | ADC | yes | one shot | F |
| ----- | | | | |
| yes | field | no | one shot | H |
| yes | field | no | repetitive | I |
| yes | field | yes | one shot | J |
| yes | field | yes | repetitive | K |
| ----- | | | | |
| yes | ADC | no | one shot | L |
| yes | ADC | no | repetitive | M |
| yes | ADC | yes | one shot | N |
| yes | ADC | yes | repetitive | O |
| ----- | | | | |
| Reset of the instrument | | | | CTRL G |
| Reset counter for coefficient output | | | | Y |
| Output the coefficients of the calibration table | | | | Z |

As has been mentioned previously, several teslameters can be connected in parallel to the same controlling device, i.e. all teslameters receive the same signals from the controller and also reply to the controller via a common line. Such a connection requires a simple adapter between the teslameters and the controller which respects the input-output port characteristics of the teslameters. Of course, only one teslameter can be commanded or read at a time over the common line. An addressing scheme, which is implemented by the program, allows the selection and control of each teslameter individually. The address of the teslameter is defined by switches on the circuit board and may range from 00 to 15, allowing a maximum number of 16 teslameters to be connected in parallel.

The address decoding in the teslameter is handled by the interrupt routine. Each teslameter can be in either of two states, the addressed state or the unaddressed state. In the addressed state, characters received on the teletype input port are loaded into a command stack which can contain ten commands at a maximum. The main program then empties the stack and executes the commands in the order of their arrival. In the unaddressed state, all incoming characters are checked whether they form the teslameter address. The addressed state is entered upon reception of the character string /<address>, with an address ranging from 00 to 15 and corresponding to the address selected on the circuit board. The unaddressed state is entered upon reception of a linefeed (LF) character. The carriage return character (CR) is ignored by the teslameter. The method of handling the teletype input by an interrupt routine has the advantage that the current execution of commands is not affected by incoming new commands and by address decoding.

The output of measurements via the teletype port is of the form

```
!<address><error code><figure in E13.6 format> LF CR  
e.g. !060+0.123456E-01 LF CR
```

The error code gives information on the ADC and the Hall-plate temperature control status. ADC underflow adds one to the error code, ADC overflow adds two and Hall-plate temperature out of range adds four to it. If no error condition is present, the error code is 0. The mentioned error conditions are also displayed on the front panel.

If the teslameter is connected to a controller which sends an echo character for each received character, the echoed characters might be taken as commands by the teslameter. To avoid this, the teslameter has an "echo mode" activated by a switch on the circuit board. In this mode, the teslameter outputs only if it is in the unaddressed state and it expects an echo after each character before the next character is sent. This also provides a means of controlling the output speed of the teslameter in as much as the controller can delay the echo of a character after having received it until it has treated it properly. This may be important if the teslameter is connected as a peripheral device to a time shared computer, where the response time may be longer than the time between characters sent by the teslameter.

The only command which is always executed as long as the teslameter is in remote position and irrespective of the addressing mode is CTRL G. After reception of this command, all activities are finished and a reset is made. The instrument is then in the same state as after switching the power on. The default command executed then is I (see Table 2). A reset is also forced by switching the instrument from the local to the remote mode or vice versa.

Appendix 1 gives an example of how to use the commands of Table 2 if several teslameters are connected in parallel to a computer.

A big advantage of using a microprocessor in the teslameter is the possibility of introducing a test program instead of the normal operating program. In this way, a large part of the digital circuitry can be tested and a rapid means of checking the performance of the principal functions and elements is provided.

5. THE CALIBRATION

5.1 Method

For a constant driving current and at constant temperature, the Hall voltage depends almost linearly on the field, the deviations from linearity being of the order of a few per cent. For precise measurements, each Hall plate has to be calibrated individually. This is done by measuring the Hall voltage at different and precisely known field levels covering the field region foreseen to be explored. At intermediate points, the field values are interpolated from the calibration points.

Experiments have shown that a third order spline fit through the measured calibration points is very well suited for the calculation of the field from the Hall voltage over the whole range. This method of interpolation has, unlike a polynomial fit, the advantage of always giving a very smooth curve which exactly goes through the measured points. It is especially well adapted for interpolating between points, which are measured with high precision. The calibration points need not be equidistant.

A third order spline fit has the following properties:

- The interpolation between two adjacent measured points is given by a third order polynomial. This polynomial is different for each interval between measured points.
- At the measured points, the values of the left hand and the right hand polynomial are the same and correspond to the measured value. Furthermore, the first and the second derivative are also the same. This guarantees that the interpolation curve goes smoothly through the measured points.
- Beyond the two end points, the third order polynomial is replaced by a straight line.

The algorithm to compute the coefficients of the interpolating polynomials from the measured points is described in Ref. 2. The routine SPLIN2 contained in the CERN Computer Program Library can be used for this purpose.

A minimum of four calibration points is necessary for the above method to work. Each calibration point adds five constants to the calibration table, four for the polynomial and one for the range limit. The maximum size of a calibration table which can be contained in the memory of the teslameter corresponds to about 60 calibration points.

To find the field value corresponding to a measured Hall voltage, the program in the teslameter first determines the interval between the nearest two calibration points. It then calculates the third order polynomial using the correct set of coefficients and the measured Hall voltage as argument. The whole computation takes about 0.2 s.

5.2 The calibration set-up

Depending on the number of teslameters to be calibrated, some degree of automation of the calibration procedure may be desirable. A description is given below of the set-up which has proven useful for the calibration and testing of a small series of 16 teslameters.

The head containing the Hall plate and an NMR measuring head are mounted together in the gap of a reference magnet. To obtain reproducible results, it is important that the support of the probe is sufficiently stable to guarantee an exact positioning between the poles of the magnet. The teslameter is connected to a minicomputer. At different field levels, the exact field value as measured by the NMR device is manually entered into the computer, whereas the corresponding Hall voltage is read automatically (using the command N - see Table 2). After each measured point, the computer calculates or updates the resulting spline fit interpolation constants. As the computer also contains the same interpolation algorithm as the teslameter, it is possible to check the quality of the interpolation between the measured points while the calibration is done. For this, a field level between two already measured calibration points is chosen and the Hall voltage is measured. The computer then finds the field value interpolating between the already available calibration data. If the correspondence with the exact NMR field value is not satisfactory, the measured point can be added to the calibration table, thus forcing the match between the interpolated and measured value. This sequence is repeated until a satisfactory agreement between measurement and interpolation is obtained over the whole range of interest. Experience has shown that an average of ten calibration points is sufficient to obtain an interpolation error smaller than 10^{-4} over the whole range of 0 to 1.3 T.

Once the calibration table is complete, the computer is used to command a programming device for read-only memories. The calibration data along with the teslameter program is written into a memory chip, which is then inserted into the teslameter. This completes the calibration of the teslameter. For control purposes, the calibration table can be extracted from the teslameter with the commands X and Y (Table 2).

It should be pointed out that the calibration data obtained in the above manner accounts for the combined effects of several errors, i.e. nonlinearities and offsets of the Hall plate, the input amplifier and the ADC.

6. CONCLUSION

The performance of the prototype teslameter was carefully evaluated and the instrument was subjected to extensive tests. These tests, including a stability test over six months, showed an error of less than 10^{-4} of full scale at the calibration points. The error for arbitrary field values can be brought to the same level by taking a sufficient number of calibration points.

Already during the design of the teslameter, it became apparent that a larger number would be needed than the foreseen five instruments for the ISR field display. In fact, another eleven teslameters were required for the magnetic mapping of a large experimental magnet, the Open Axial Field Magnet (OAFM) for the ISR, and still other equally important applications are in view. This confirms the initial decision to build a universal instrument rather than one suited only for the original purpose.

These 16 teslameters are now completed and in use. Measurement checks on this small series also confirm the results obtained with the prototype.

In the case of the OAFM, it has been seen that the connection of ten teslameters to a minicomputer over a common input line is straightforward and gives no problem either for the software or for the hardware.

The teslameters for the ISR field display, for which this project was initiated, are currently operational and the field measurements correspond to within 10^{-4} with the values obtained with the previous moving coil system.

7. SPECIFICATIONS

- Hall probe current : 100 mA
- Range of Hall voltage : adjustable by internal resistors.
A minimum of 100 mV is required for full scale reading.
- Temperature of the Hall plate : 35°C
- Heating time from power on to stable temperature : < 5 min. Stable temperature is reached when the probe temperature indicator is off.
- Range of ambient temperature : 15 to 30°C
- Resolution of the ADC converter : 16 bits, i.e. 15×10^{-6} of full scale either unipolar or bipolar
- Precision of measurement : 10^{-4} of full scale or 10^{-4} T whatever is bigger. For this precision, it is recommended to let the teslameter warm up for about 30 min after switching the power on.
- Conversion time : 200 ms, i.e. 10 periods of mains
- Calculation time : ~ 0.2 s
- Front panel display : digital display of the result. Error status: overflow, underflow, temperature out of range.
- Front panel switches : mode selection and triggering of measurements in local operation
- Remote control : Input of commands and output of measurements via a 20 mA teletype current loop. Baud rates: 110, 300, 1200, 2400, 4800, 9600, 19200, 38400. Echo mode selectable by an internal switch.
- Mass : 3.6 kg
- Power requirements : 220 V a.c., 30 W

Acknowledgements

The authors would like to thank L. Resegotti and J.P. Gourber for the encouragement and for helpful discussions during the design of the teslameter, as well as M. Nicod for the careful and precise fabrication of many prototypes of the mechanical parts.

REFERENCES

- 1) K.N. Henrichsen and J.P. Gourber, The computer controlled system for the forecast of beam parameters in the CERN Intersecting Storage Rings, Proc. VIIIth Int. Conf. on High Energy Accelerators, CERN 1971, and Div. Report CERN ISR-MA/71-37 (1971).
- 2) Ed. A. Ralston and H. Wilf, Mathematical methods of digital computers, Vol. 2, Chapter 8, Wiley, New York (1967).

APPENDIX 1

Illustrative example of messages between two teslameters and a computer
(the teslameters are connected to a common line)

| Step | Computer to teslameter | Teslameter to computer | Comment |
|------|------------------------|-------------------------|----------------------------------------------------------------------------------------------------------------------------------------------------------------------------------|
| 1 | CTRL G CR LF | | The computer resets both teslameters. |
| 2 | /00H CR LF | | The computer addresses the teslameter 00, asks for a field measurement without output of the result. Carriage return (CR) is ignored, line feed (LF) unaddresses the teslameter. |
| 3 | /01H CR LF | | While the measurement in teslameter 00 goes on, the computer starts the same measurement in teslameter 01. |
| 4 | /00B CR LF | | The computer now commands teslameter 00 to send the result of the measurement started in step 2. |
| 5 | | !000-0.123436E+00 LF CR | Teslameter 00 responds after having completed its measurement. The measured field is -0.1234 T. The six transmitted mantissa digits do not imply a precision of that order. |
| 6 | /01B CR LF | | The computer asks teslameter 01 to send its result. |
| 7 | | !014-0.234567E-01 LF CR | Teslameter 01 responds. The result may be incorrect, because the error code 4 indicates that the Hall-plate temperature is out of range. |
| 8 | /01F CR LF | | The computer now asks teslameter 01 to send the ADC value of the same measurement. |
| 9 | | !014+0.112230E+05 LF CR | The ADC value is sent. |

APPENDIX 2

Function selection switches on the printed circuit board

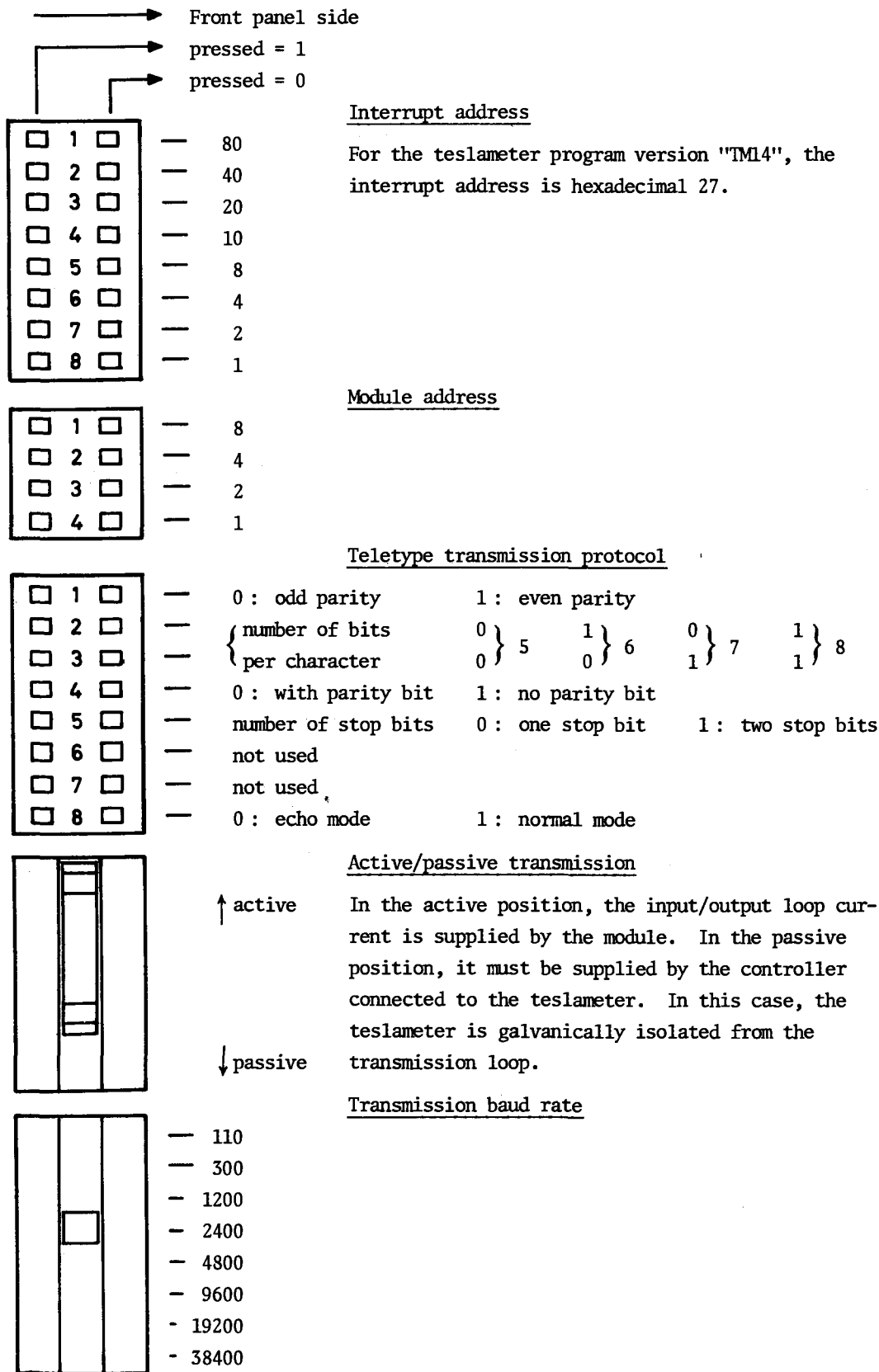

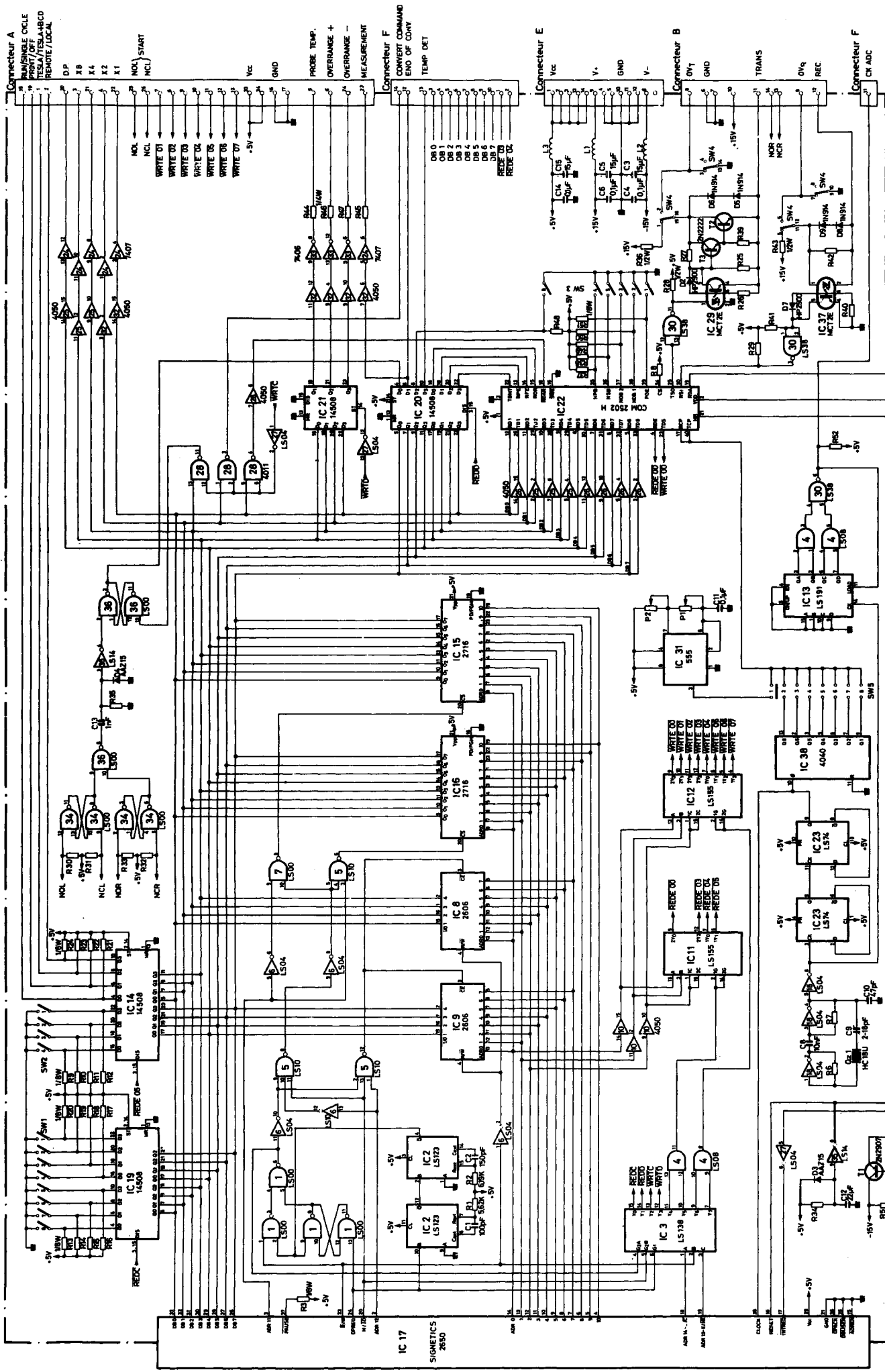

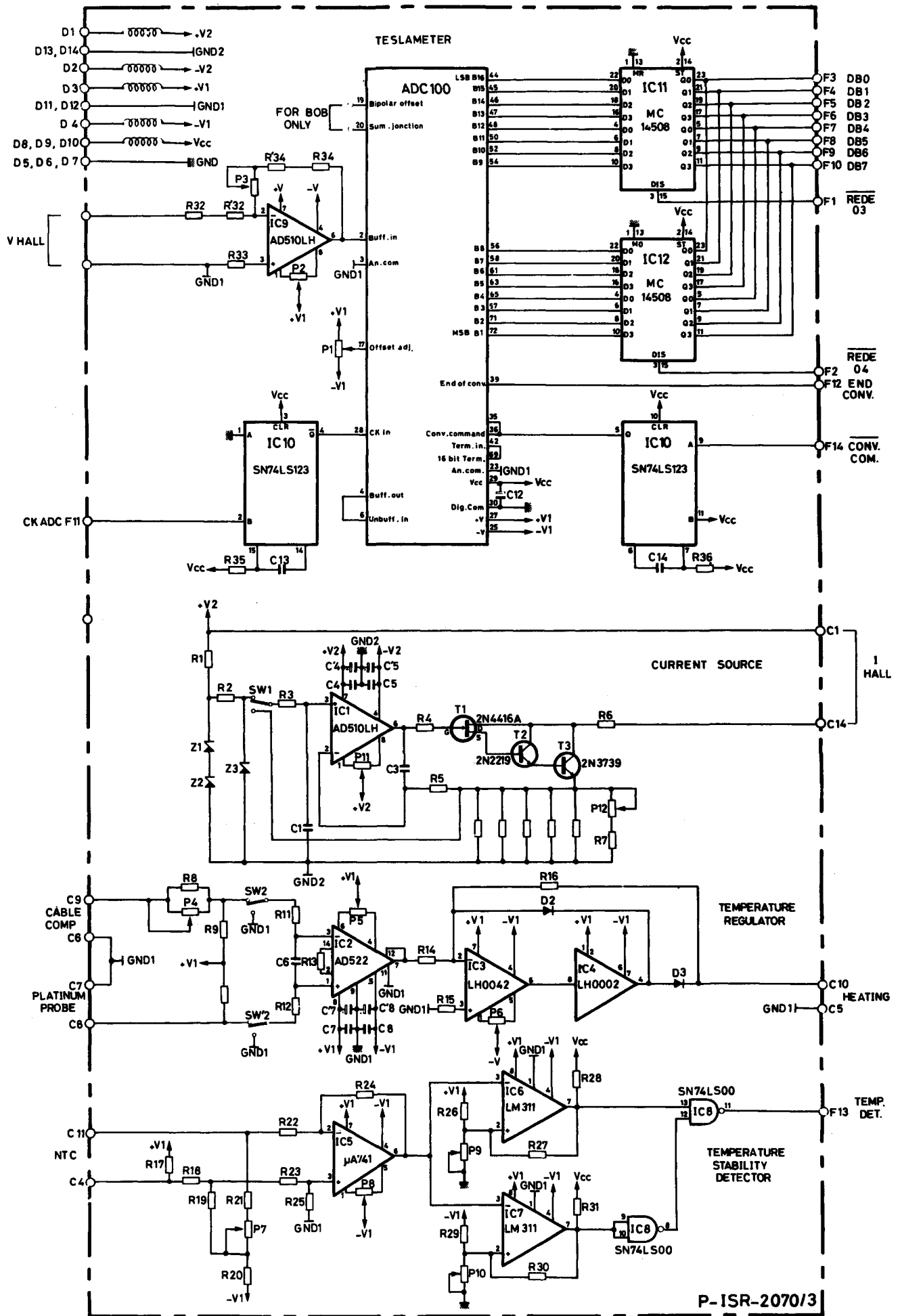

Teslameter - Hall probe driver/monitor

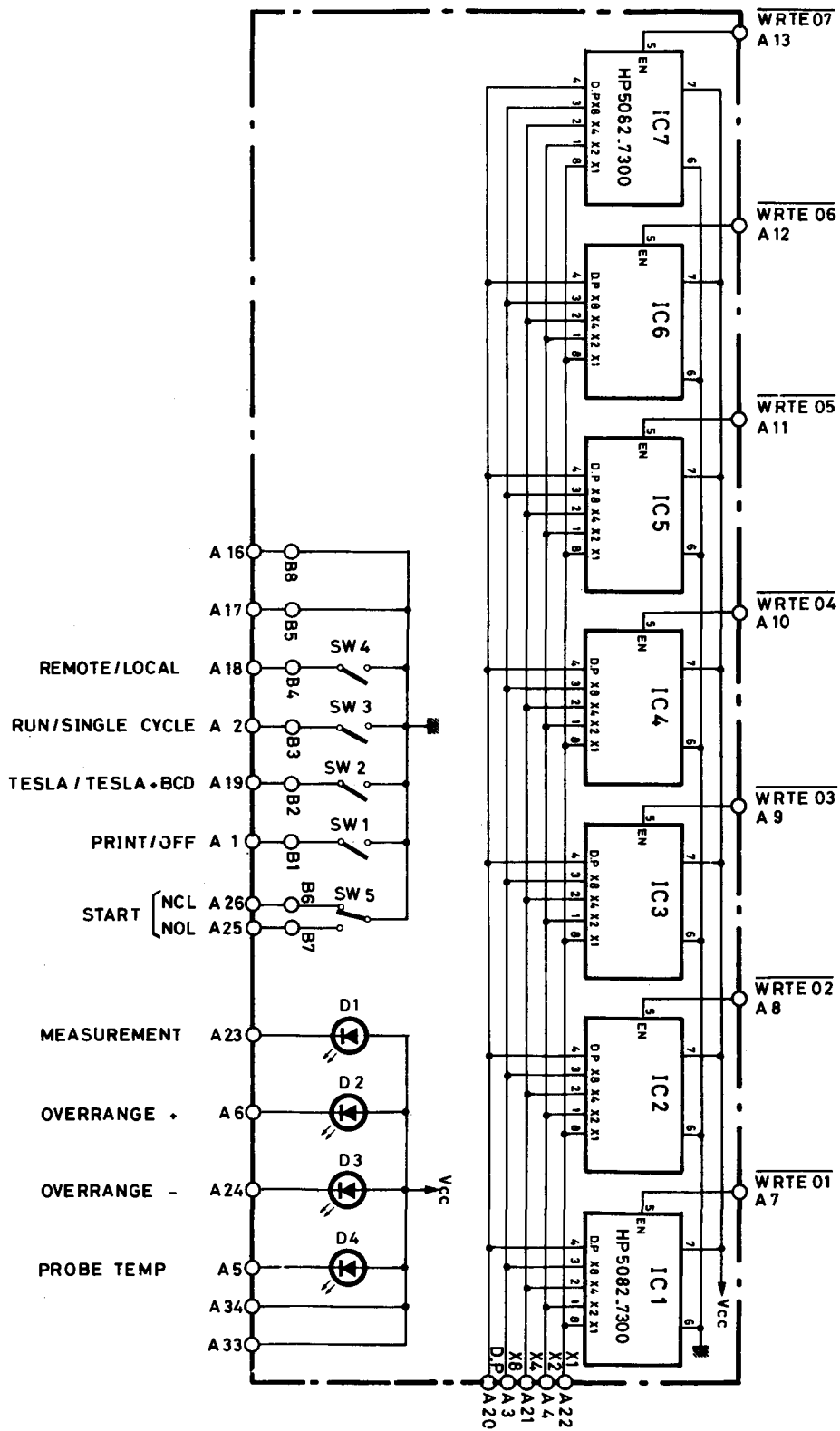

C-ISR-2070/4 1A

Teslameter - Display